



## **1RU 17.3" LCD Console Drawer with Integrated DVI KVM Switch - 12 Port**

### **User Manual**

**SAIS - Sacasa Industries & Systèmes**  
8 rue André Marie Ampère  
28500 Vernouillet - France  
09 70 440 600 - (+ 33) 970 440 600  
<https://clavier-ecran-rackable.fr>  
[contact@sacasa.info](mailto:contact@sacasa.info)

---

# Contents

<b>1. Introduction</b>	<b>3</b>
1.1 Main Features	3
1.2 Package Contents	3
1.3 LED Panel	4
1.3.1 Port LED Indications	4
1.3.2 7-seg port LED	4
1.3.3 Buttons and Operations	4
1.4 Back Panels	5
1.5 USB2.0 Hub (at Front)	5
<b>2. Hardware Installation</b>	<b>6</b>
2.1 Computer/Server Installation	6
2.1.1 Connecting KVM switch to the host system	6
2.2 Power Up Sequence	7
<b>3. Usage</b>	<b>7</b>
3.1 Hotkey Commands	8
3.2 DDC function	8
3.3 Hot Plug	8
3.4 Firmware Upgrade	9
<b>4. Technical Specifications</b>	<b>11</b>
<b>5. Troubleshooting</b>	<b>12</b>
<b>6. Glossary</b>	<b>13</b>
<b>7. Certifications</b>	<b>14</b>

---

## 1. Introduction

The 8-port DVI LCD KVM Switch including DVI-I, Single-Link, USB 2.0 and stereo audio. The DVI KVM Switch allows you to control up to 8 computers with DVI display output from a single keyboard, mouse and monitor.

It supports both digital video (1920 x 1200) and analog video (1920 x 1200) for your maximum convenience in adapting to your display requirements. It also offers two USB 2.0 device hub ports for high-speed USB device sharing. Its Audio switching function offers you uninterrupted multimedia experience while performing KVM Switching with multi-platform support for PC, Macintosh G4/G5 and iMAC. We also offer various hotkey alternatives for free configuration. It supports HDCP compliant for digital contents protection. This KVM Switch also allows its user to upgrade firmware contents whenever needed to enhance compatibility or functionality.

### 1.1 Main Features

- One USB console controls 8 Single Link DVI computers and 2 additional USB 2.0 devices
- 3 port USB 2.0 hub build in; 2 locates at rear and 1 locates at front
- Supported USB HUB switching independent
- Supported audio output switching independent
- Build in 2 x 2 watts stereo speaker
- Supported video resolution up to 1920x1200
- Support Microsoft Windows, Netware, Unix, and Linux
- Support iMAC, Power MAC and Sun Micro Systems with USB port
- No Software Required – easy computer selection via Push Buttons, Hotkeys
- Provide various Hotkey (Scroll-Lock/ Caps-Lock/ Num-Lock/ Alt/ Ctrl/ Win) for switching computer port and other control functions, so Hotkey function can be used in various types of keyboards, and to avoid Hotkey duplicate problem
- Keyboard status restored when switching computers
- Support Mac/Sun keyboard emulation

### 1.2 Package Contents

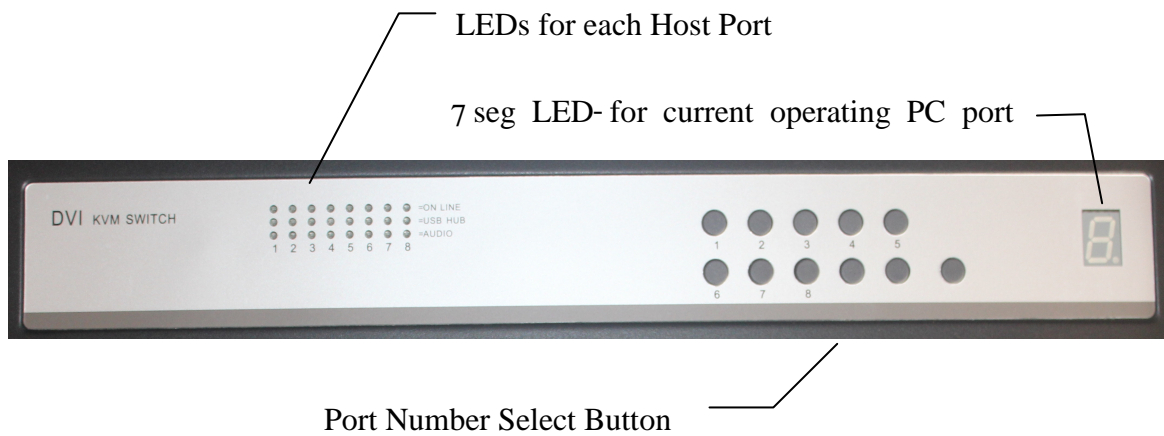
1 x LCD Console Drawer with Rack Mounting Sliding Rails

1 x AC Power Cable

1 x CD-ROM with User Manuals, Quick Installation Guides and Utilities

---

## 1.3 LED Panel



**Figure 1. LED Panel View**

### 1.3.1 Port LED Indications

**There are three LED's for each port:**

- **ONLINE LED:** The **Red** LED on indicating a Computer is connecting to the port.  
Notice: The PC99 Computer always power on the USB ports and turn on Red LED even if the Computer is not power on.
- **USB HUB LED:** The **Green** LED on indicating the USB HUB in which port.
- **AUDIO LED:** The **Blue** LED on indicating the Audio in which port.

### 1.3.2 7-seg port LED

The 7-segment port LED indicates the current operation PC port. It always shows “1” at this application.

### 1.3.3 Buttons and Operations

There are 8 push buttons on the LED panel. The operations described in below.

(1) The “1”, “2”, “3”, “4”, “5”, “6”, “7”, “8” are the port number select buttons

You can select to the required port number by press the port number to switch the port directly.

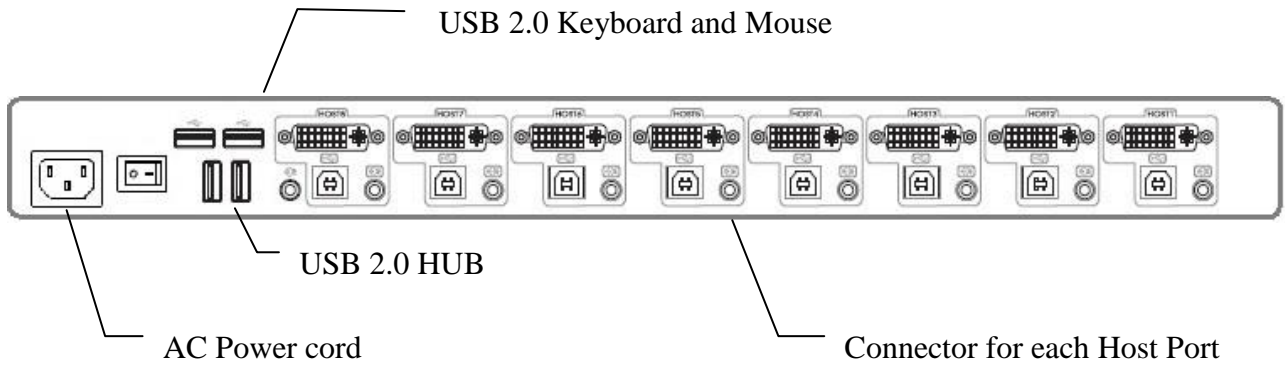
The current operating computer port will be displayed at the 7-Segment LED.

(2) If you pressed the invalid operation, the system will stay at the previous selected port.

(3) The other buttons are not valid

---

## 1.4 Back Panels **NOW with 12 DVI-D PORTS**



**Figure 2. Back Panel View**

## 1.5 USB2.0 Hub (at Front)

It provides a front port USB2.0 HUB for convenient access the USB devices at front.

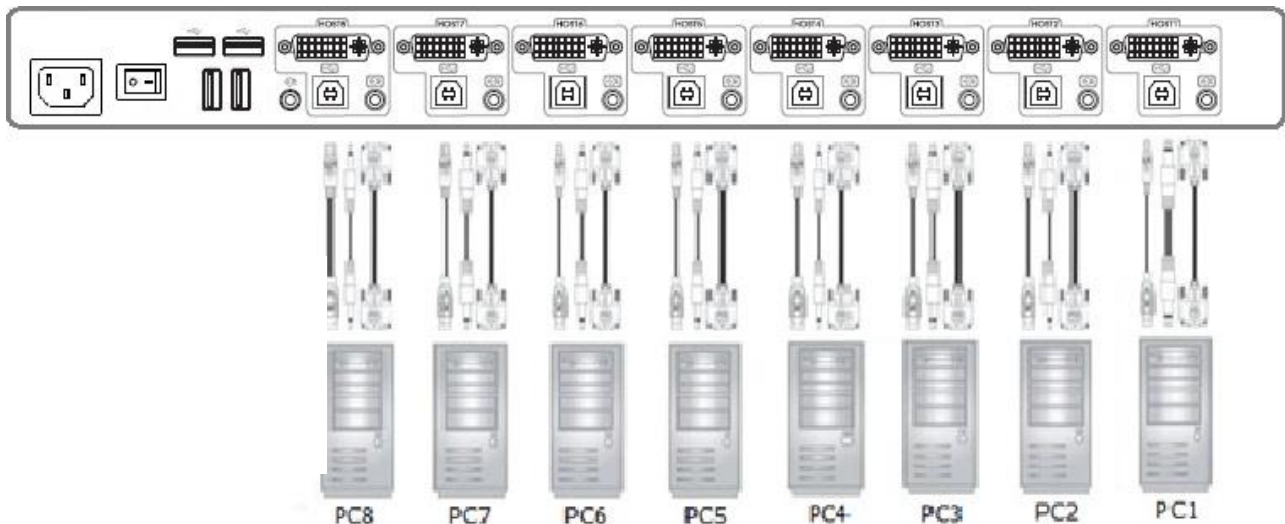


---

## 2. Hardware Installation

Before installation, please make sure all of peripherals and computers have been turned off.

### 2.1 Computer/Server Installation



**Figure 3. Computer/Server Installation**

#### 2.1.1 Connecting KVM switch to the host system

In order to connect the KVM switch of the host system performs the following steps:

**Step 1.** Power up you KVM Switch by connecting the power cord to it.

**Step 2.** Connect the shared USB keyboard, mouse and speaker as well as other shared USB devices to the KVM switch.

**Step 3.** Connect each of your computers to the KVM switch, using the DVI video cable and USB (Type A-to-Type B) cable and audio cables).

**Step 4.** Power up the connected computers one by one. After your computers are powered up, the keyboard and mouse will be recognized and now you can begin operating the KVM switch.

---

## 2.2 Power Up Sequence

Double check whether all cables/connectors are properly connected. You can check the keyboard and mouse connectors to ensure the connectors and cables are connected correctly.

**The recommended Power Up sequence is as follows: Monitor, KVM Switch, finally the Computers.**

Verify that all servers connected to the KVM Switch are powered on. If any connected servers have not been powered on, it is okay to do so at this time (servers can be powered on simultaneously).

The KVM Switch emulates both a mouse and keyboard on each port and allows your server to boot normally.

When power on the KVM switch, you will see the 7-Segment LED displayed Port 1 lights up, and hear a beep sound. If you encounter an error, check your cable connections for that server and reboot. If the problem persists, please refer to the chapter “Troubleshooting” in this User Manual.

## 3. Usage

Now that you have connected your console and servers to your KVM Switch, it is ready for use.

You can control the KVM switch by two methods:

1. Using push buttons located on the LED panel of the KVM Switch
2. Using hot-key commands through the console keyboard

It takes few seconds for the video signal to refresh after switching servers. Re-synchronization of the mouse and keyboard signals also occurs. This is normal operation and ensures that proper synchronization is established between the console and the connected servers.

---

### 3.1 Hotkey Commands

You can conveniently control the LCD console drawer through simple keyboard Hotkey sequences. To send keyboard Hotkey commands to the LCD drawer, you must **press the Hotkey** (default Hotkey is **Caps Lock + CapsLock**) **within 2 seconds**. You will hear a beep sound confirming you are entering the Hotkey mode. If you do not press any key during Hotkey mode within 2 seconds, the Hotkey mode will be disabled and return the keyboard back to its normal state.

The default Hotkey is **Caps Lock + Caps Lock**, then the keys on the following table list.

Command	Function
↑ or ↓	Move selection up or down
1 ~ 8	To switch port 1 ~ port 8
F1 ~ F8	To Switch Audio of Port 1 to Port 8
B	To enable/disable <b>beep sound</b> function.
S	To activate the <b>Auto-scan</b> function.
H	To switch USB HUB to current operating PC port.
A	Switch to current operating PC port's audio output.
G	To switch audio output & USB HUB to current PC port.
F	To enable <b>Firmware upgrade</b> function

### 3.2 DDC function

The KVM Switch support DDC (Display Data Channel). DDC is a VESA standard for communication between a monitor and a video adapter. Using DDC, a monitor can inform the video card about its properties, such as maximum resolution and color depth. The video card can then use this information to ensure that the computer is presented with valid options for configuring the display.

**Note:** The DDC function of KVM Switch will dynamically detect and copy the DDC data from the monitor, and that data will feed to the host computer during computer startup.

### 3.3 Hot Plug

The KVM Switch supports “Hot Plug” function for USB keyboard and mouse connectors.

**Note:**

- Normally, USB port is Hot pluggable, but some OS (Operation Systems), like Sun Micro and some Unix and Linux, do not support USB Hot Plug function. If you apply Hot Plug to this kind of OS, it will cause unpredictable behavior or shut down the Computer. Before attempting to use Hot Plug, please make sure OS and mouse software driver support the Hot Plug function.



---

### 3.4 Firmware Upgrade

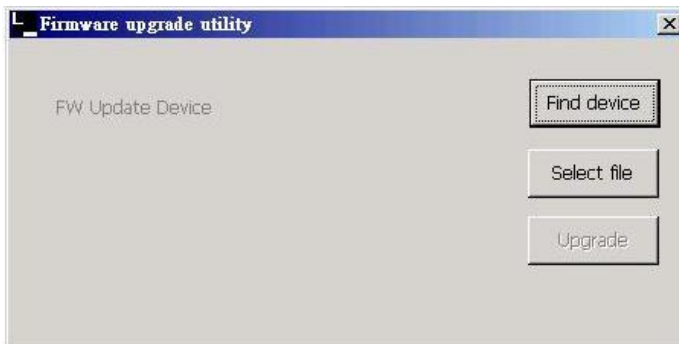
Please follow the following procedures:

1. Power on the KVM unit. Use the USB Type-A to Type-B Cable connect between KVM port1 and PC USB port. Then press Hokey + Hokey + F, appears “Beep” sound. At this time, The KVM console will have no response.
2. The KVM now will be into upgrade mode, waiting for firmware download.
3. Unplug the KVM mouse and Keyboard, Connect the mouse to the Computer directly, Run “Firmware Upgrade Utility.exe”

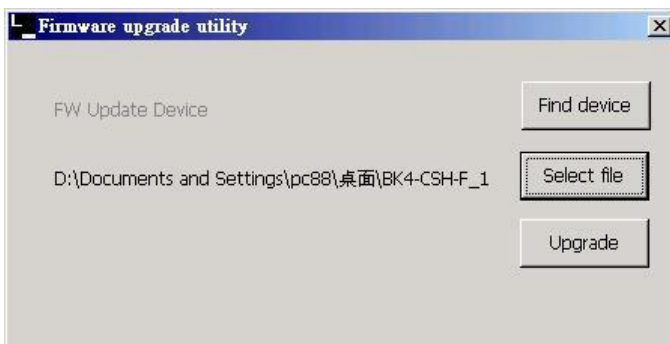


**Figure 4. Run Firmware Upgrade Utility**

4. Click **Find device** to Found KVM unit, and to select the FW upgrade file. Please make sure you select the correct FW upgrade file.

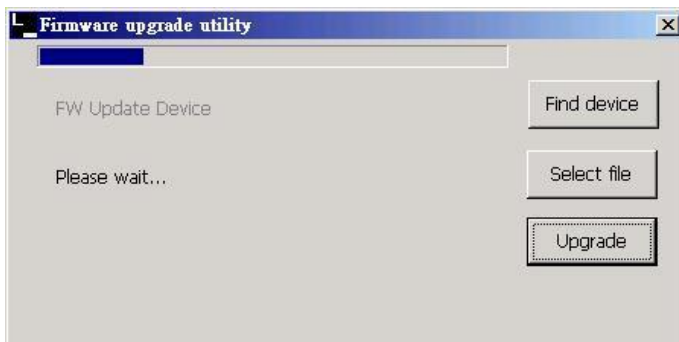


**Figure 5. Find Device**



**Figure 6. Select Firmware Upgrade firmware File**

- 
5. Click **upgrade**, start to upgrade. The upgrade process takes about 6-10 seconds, then display **Upgrade OK and please reset your device** if complete the upgrade successfully.



**Figure 7. Start to Upgrade**



**Figure 8. Firmware Upgrade finished**

6. Now the KVM unit should be running on the new firmware.

---

## 4. Technical Specifications

Feature	Specification
Host Port Connector	KB/MS : USB B Type Video : DVI-D Single Link (digital) Audio : 3.5mm phone jack(Green)
Host Ports	8
Max. Distance (KVM switch -- Host)	16 feet (5m)
Video Resolution	Up to 1920 x 1200
Console Audio Output	3.5mm phone jack x 1
USB 2.0 HUB port	1 x USB2.0 Type-A connector (front) 2 x USB2.0 Type-A connector (rear)
Computers Selection	(1) Hotkey (2) Push button
Hotkey	Caps-Lock
Computer Port LED's	3 x LED's per Host port: ON LINE (Red) USB HUB (Green) Audio (Blue)
Auto-Scan Intervals	Fixed time
Flash upgrade	Through port 1 USB port (need to use hotkey F to enter to flash mode)
Housing	Metal
Operation Temperature	0 ~ 50°C
Storage Temperature	-20 ~ 60°C
Humidity	0 ~ 95%, Non-Condensing
Mechanical	19" Rack mount ,1U
Dimension ( W x H x D )	447.6 x 42 x 580 (mm)

---

## 5. Troubleshooting

1. No LED display on KVM Switch
  - Make sure the power adapter plugged into the KVM Switch. If the LED's still won't light, perform soft reset to KVM switch.
  - Power cycle KVM switch.
2. The computer has started up, but keyboard or mouse won't work
  - Make sure your keyboard and mouse work fine if directly plugged into the computer.
  - Please unplug and plug in the USB connector, wait few seconds for USB bus emulations and start up process to complete.
  - Do not press any keys on the keyboard while the selected computer is booting up. Otherwise it might cause the keyboard error or keyboard is not detected at Host side.
  - Try a different keyboard, but use only 101/102/104-key keyboard.
  - Power cycle KVM switch.
  - Avoid moving the mouse or pressing the mouse buttons when switching ports.
3. No video signal is displayed on the LCD monitor.
  - Connect another monitor directly to the server to verify that your monitor is functioning properly.
  - Please check if all connectors are connected properly
  - The power adapter is not connected to the KVM switch.
  - See next item, make sure the computer VGA output resolution match with the monitor's resolution
4. The computer resolution does not match the monitor's resolution
  - Make sure the resolution works fine if directly connect the monitor to the computer.
  - Please turn off the computer, wait few seconds then turn on again. Notice that during computer startup, it will try to obtain the information of the connected monitor resolution from its related port. So before computer startup, the monitor and KVM switch should be already ON and running.
  - The DDC function of KVM Switch will dynamically detect and copy the DDC data from the monitor that attached to the **LOCAL console port**, and that data will feed to the host computer during computer startup.
  - The recommended Power ON sequence is as follows: monitor, KVM Switch, finally the computers.

---

## 6. Glossary

The following definitions are used throughout this User Manual.

- **Auto-Scan:** A mode of operation where the KVM switch scans from one port to another, on an ongoing basis, as configured by the user.
- **Console:** The all-in-one term for the keyboard, video monitor, mouse, and audio connected to a KVM switch.
- **Console Port:** An interface receptor on the KVM switch for the console to connect to the KVM switch via cables.
- **Control:** When discussing switching between ports, control means that the console is capable of sending input to the server. Control requires that the console also has focus on the port, and is viewing it.
- **DDC:** Short for Display Data Channel, a VESA standard for communication between a monitor and a video adapter. Using DDC, a monitor can inform a computer's video card about its properties, such as maximum resolution and color depth, to ensure that the user is presented with valid options for configuring the display.
- **HID:** Human Interface Device, the USB device class that includes keyboards and mice.
- **Host/Computer Port:** An interface receptor on the KVM switch for the computer/server to connect to the KVM switch via cable.
- **KVM:** Literally "Keyboard Video Mouse", this term refers to technology that allows two or more computers to be controlled by one keyboard, video monitor, and mouse; some switches that use KVM technology enable sharing of other peripherals such as audio speakers, microphones, and printers.
- **KVM Switch:** A device that allows a user to access and control multiple servers from a single console. It has at least one console port and multiple server ports.

---

## 7. Certifications

### FCC

This equipment has been tested and found to comply with Part 15 of the FCC Rules. Operation is subject to the following two conditions:

- (1) This device may not cause harmful interference
- (2) This device must accept any interference received. Include interference that may cause undesired operation.

### CE

This equipment is in compliance with the requirements of the following regulations: EN 55 022: CLASS B.

### RoHS

All contents of this package, including products, packing materials and documentation comply with RoHS.



**SAIS - Sacasa Industries & Systèmes**  
**8 rue André Marie Ampère**  
**28500 Vernouillet - France**  
**09 70 440 600 - (+ 33) 970 440 600**  
**<https://clavier-ecran-rackable.fr>**  
**[contact@sacasa.info](mailto:contact@sacasa.info)**