

LCD Drawer User Manual

KVM-1701SWPD-M2



This manual, covering various aspects of the equipment such as installation, setup and cascade, will help you make full use of this LCD KVM Drawer. Please read this manual carefully and install and operate the equipment according to the manual to avoid damage to this product its accessories.

Product package includes following items:

- 1 * 17.3 inch LCD KVM Drawer;
- 1 * AC Power Cord
- 1 * Rack installation bracket (one pair)
- 1 * USER'S manual (CD)
- 1 * 1.8 Meter VGA cable
- 1 * 1.8 Meter DVI cable
- 1 * 1.8 Meter USB A Type cable
- 1 * 1.8 Meter Audio cable

Please check items above. If any item is missing or damaged, please contact your dealer promptly.

Table of Contents

1	Introduction	-4-
	1.1 Overview	-4-
	1.2 Functions & Features	-4-
	1.3 Hardware Requirement	-4-
	1.3.1 Host Requirement	-4-
	1.3.2 Cables	-4-
	1.4 Product Specifications	-5-
	1.5 LCD Specifications	-5-
	1.6 Front View	-6-
	1.7 Rear View	-7-
2	Installation	-8-
	2.1 Rack Installation	-8-
	2.2 Standard Installation	-9-
	2.3 LCD KVM Console and KVM Cascade Installation	-10-
	2.4 LCD OSD Menu Setup	-11-
3	Certificates	-12-

1 Introduction

1.1 Overview

KVM-1701SWPD-M2 LCD KVM integrates keyboard, LCD display and touch pad in a drawer type worktable and provides a convenient space-saving operation mode for KVM switch technology. The cover is an LCD display, while the base is keyboard and touchpad.

KVM-1701SWPD-M2 KVM console is a control device integrating 17.3" LCD, 104 keys keyboard and touchpad mouse. You can access multiple hosts using the LCD console while saving money and efforts.

LCD KVM console is the best choice to save time and efforts. Since all hosts can be controlled from a single main control terminal, using the LCD KVM Console:(1)avoids the cost of keyboard, mouse and monitor of each host; (2) saves work space; (3) saves power; (4) saves the trouble of moving from one computer to another.

* For Mac and Sun hosts, USB cable must be used for connection.

1.2 Function & Features

KVM-1701SWPD-M2 KVM display is integrated to a drawer type worktable of 1U height to facilitate rack installation. Supported resolution up to 1920 x 1200 , 75Hz. It meets the 1U height of rack specifications and can be installed into 19 inch rack cabinet . No need to install additional software or hardware.

1.3 Hardware Requirement

1.3.1 Hosts Requirement:

- (1) DVI, VGA graphic card

Note: the max. resolution of the integrated LCD display is 1920x1200. Make sure the resolution of any connected computer does not exceed this resolution.

- (2) USB port for keyboard and mouse.
- (3) USB 2.0 Hub for peripheral USB device

1.3.2 Cables

- (1) DB-15 VGA cable male to male
- (2) USB A Type Cable
- (3) DVI-D Cable male to male
- (4) Audio Cable

1.4 Product Specifications

Model		KVM-1701SWPD-M2
Brightness		300cd/m2
Contrast		650:1
Angle of visibility		140°(H),120°(V)
Color display		262K
Keyboard		104 keys
Mouse		touch pad mouse
Local Control Terminal	Keyboard/Mouse	USB 2.0
	DVI-D	24 pin DVI-D female connector
	VGA	HD-15 female connector
	USB 2.0	For USB peripheral device
Video resolution		1920 x 1200 @75Hz
Power supply		100-240V AC 50/60Hz via IEC Type power cord
Housing		Metal housing
Weight		14Kg
Dimension(W x H x D)		443 x 42 x 406 (mm)

1.6 Front View

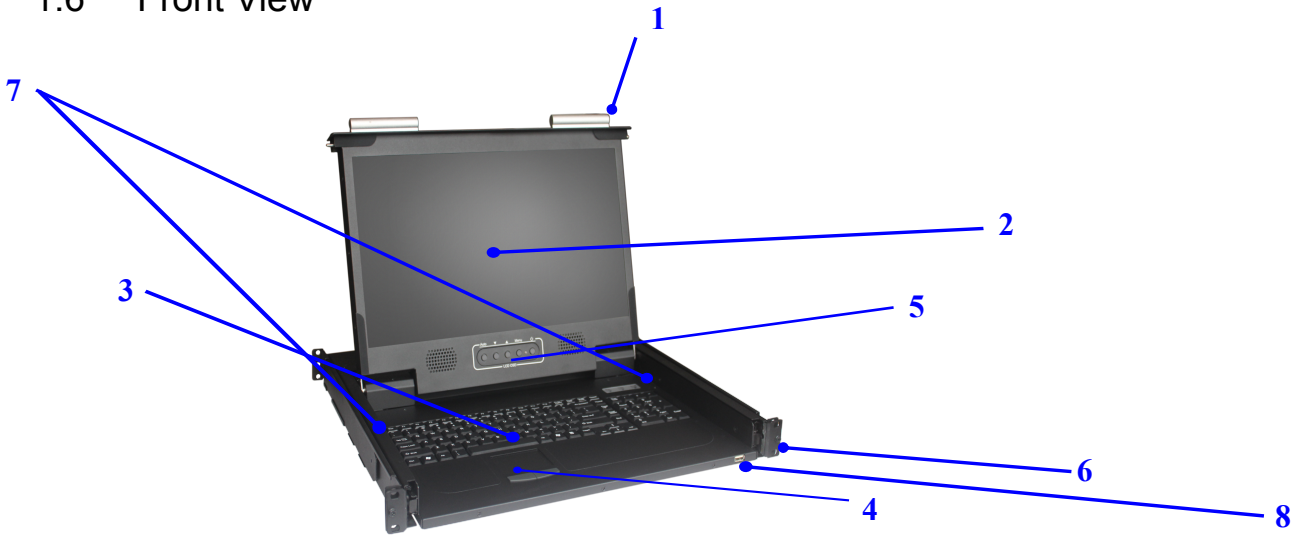

NO	Part	Function Description
1	Handle to adjust screen position	
2	LCD display	
3	Keyboard	
4	Touchpad	
5	LCD OSD button	LCD button to control Screen Display position and image setting.
6	Mounting bracket	Install into rack cabinet
7	Lock button	Auto lock / release when lcd pull up and down
8	USB2.0 HUB port	

1.7 Rear View

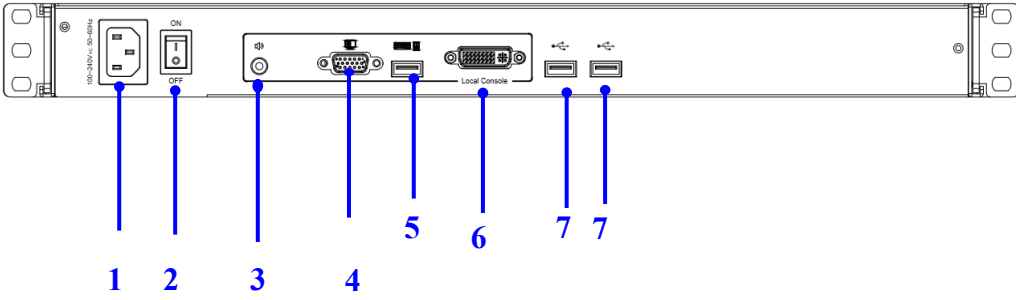

No	Component	Function Description
1	AC Power port	Standard IEC Type AC Inlet
2	Power Switch	Rock switch, turn on/off equipment main power.
3	Audio port	For audio function
4	VGA port	Connect to server or KVM.
5	USB port	Connect to server or KVM.
6	DVI port	Connect to server or KVM.
7	USB 2.0	For USB peripheral device

2 Installation

2.1 Rack Installation

Step 1

Loosen screw **A** on both sides to slide out and remove the two rear slide rails.

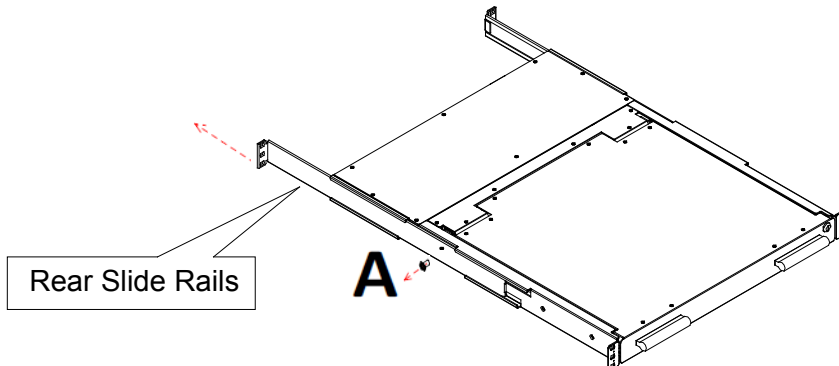

Step 2

Attach the two rear slide rails to the rear vertical mounting rails of the rack cabinet using standard M6 cage nuts and screws.

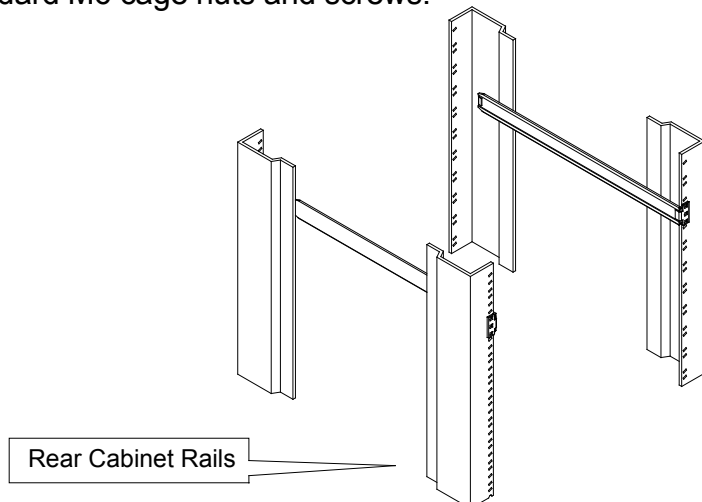

Step 3

Position the LCD console drawer so the two rear slide rails will slide into the main body of the LCD console drawer. Attach the mounting ears of the LCD console drawer to the front vertical mounting rails of the rack cabinet using standard M6 cage nuts and screws.

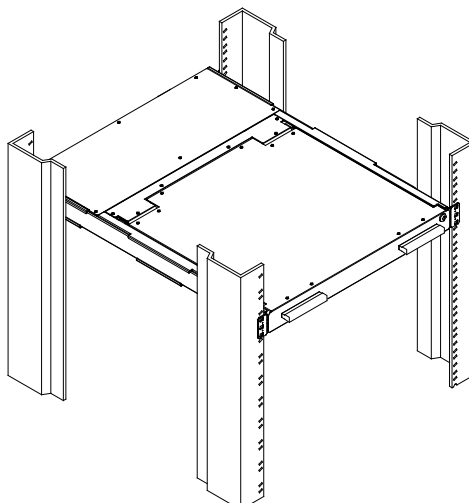

2.2 Standard Installation

Please follow the installation drawing and instructions below for standard installation:

- * Please Shutdown the Power of Equipment Needs to be Connected
- * Please Pay Attention to Earthing of Equipment

The standard installation is completed, and LCD KVM console can be powered on. Then power on connected hosts.

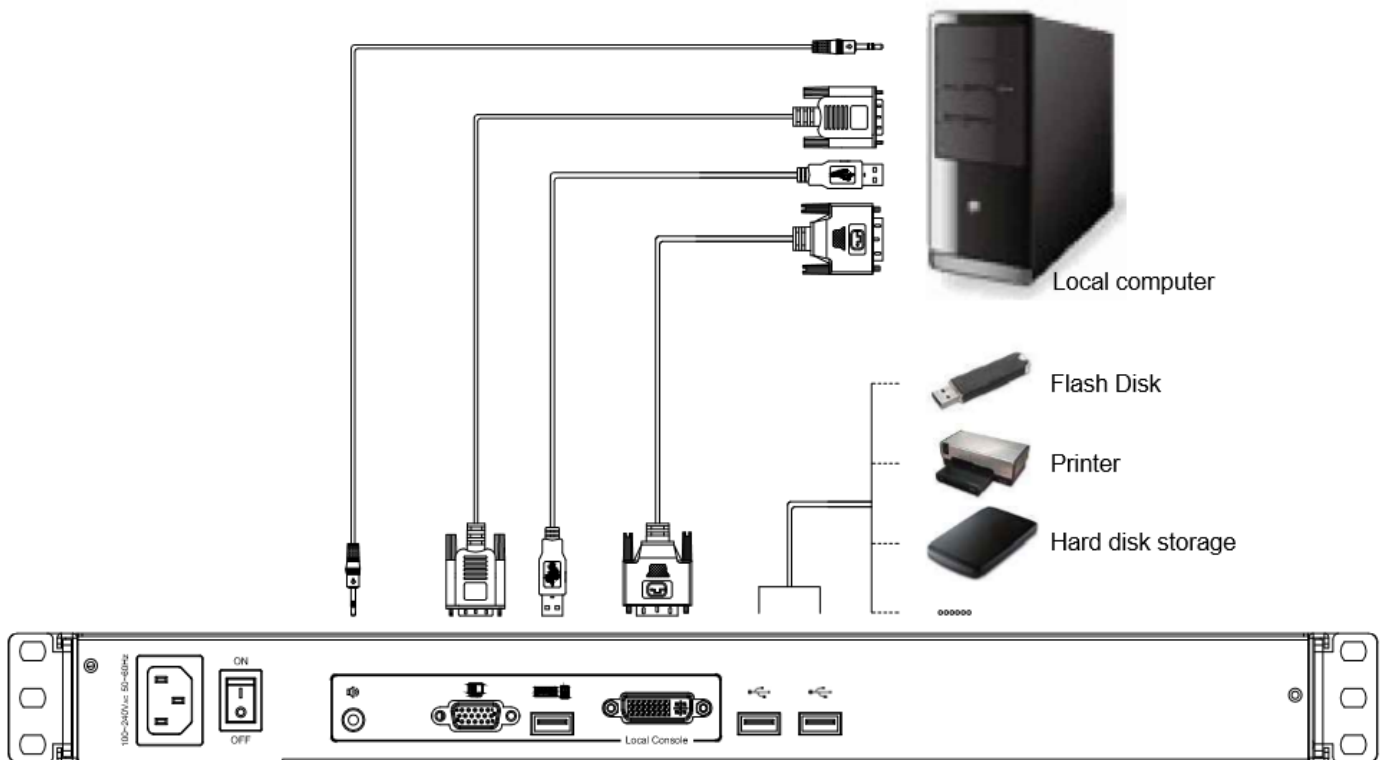

KVM-1701SWPD-REAR-COVER

2.3 LCD KVM Console and KVM Cascade Installation

LCD KVM console port can be directly connector to another KVM Switch as cascade to Perform unified management all connected hosts. Please follow the installation drawing and instructions for standard installation:

- (1) Make sure to power off all equipment to be connected and existing equipment.
- (2) Switching slide switch on USB position
- (3) Use an USB / VGA cable to connected the LCD and KVM switch console port.
- (4) Turn on the KVM and LCD console power first and then power on hosts to prevent loss of any keyboard or mouse.

Cascade connection drawing:

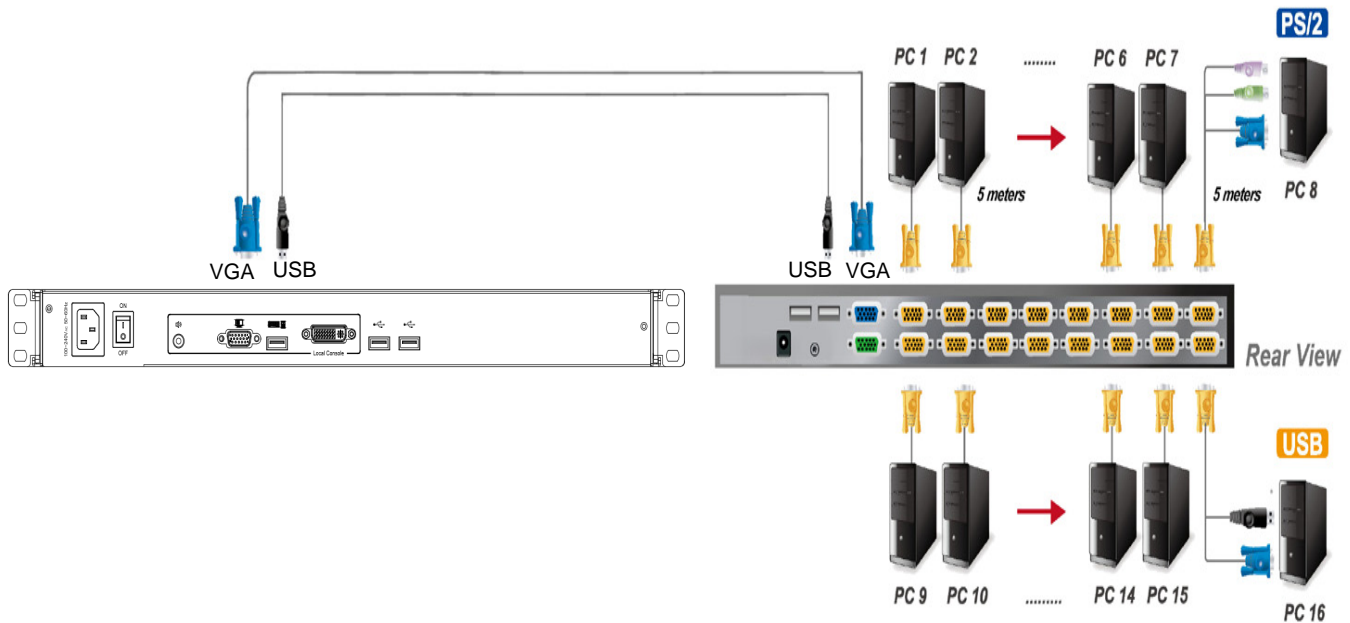

2.4 LCD OSD Menu Setup

OSD Control buttons

LCD OSD can establish and setup LCD display. Setup instructions of four buttons are as follows:

Button	Functions
POWER	Turn on or off the LCD Display
MENU	Activate OSD menu, select a menu and press MENU key to confirm the selection and enter the submenu.
▲	Press this key to increase setting or scroll up the menu bar
▼	Press this key to Decrease setting or scroll down the menu bar
AUTO	press the auto key to adjust screen display position

OSD Control Operation

Main Menu



3 Certificates

FCC

This product has been tested and is proved to meet requirements of Grade B electronic devices and specifications of Section 15 of FCC certification. Please observe following two conditions in operation that:

- (1) The equipment will not generate any harmful interruption.
- (2) If the equipment is interrupted, it may cause unnecessary operations.

CE

This equipment complies with regulations of EN55022:CLASS B.

RoHS

The whole package including products, packaging materials and documents meet RoHS equipments.